

THIS DRAWING IS UNPUBLISHED. RELEASED FOR PUBLICATION, 19 .
 © COPYRIGHT 19 BY AMP INCORPORATED. ALL RIGHTS RESERVED.

LOC	DIST	REVISIONS			
P	LTR	DESCRIPTION	DATE	DWN	APVD
G	14	C	REV / 0720-0967-96	09SEP96	ME TM

AMP WIRE RANGE	UL E13288	SP LR7189 Certified
12-10 AWG SOLID OR STRANDED	12-10 AWG SOLID OR STRANDED	12-10 AWG SOLID OR STRANDED

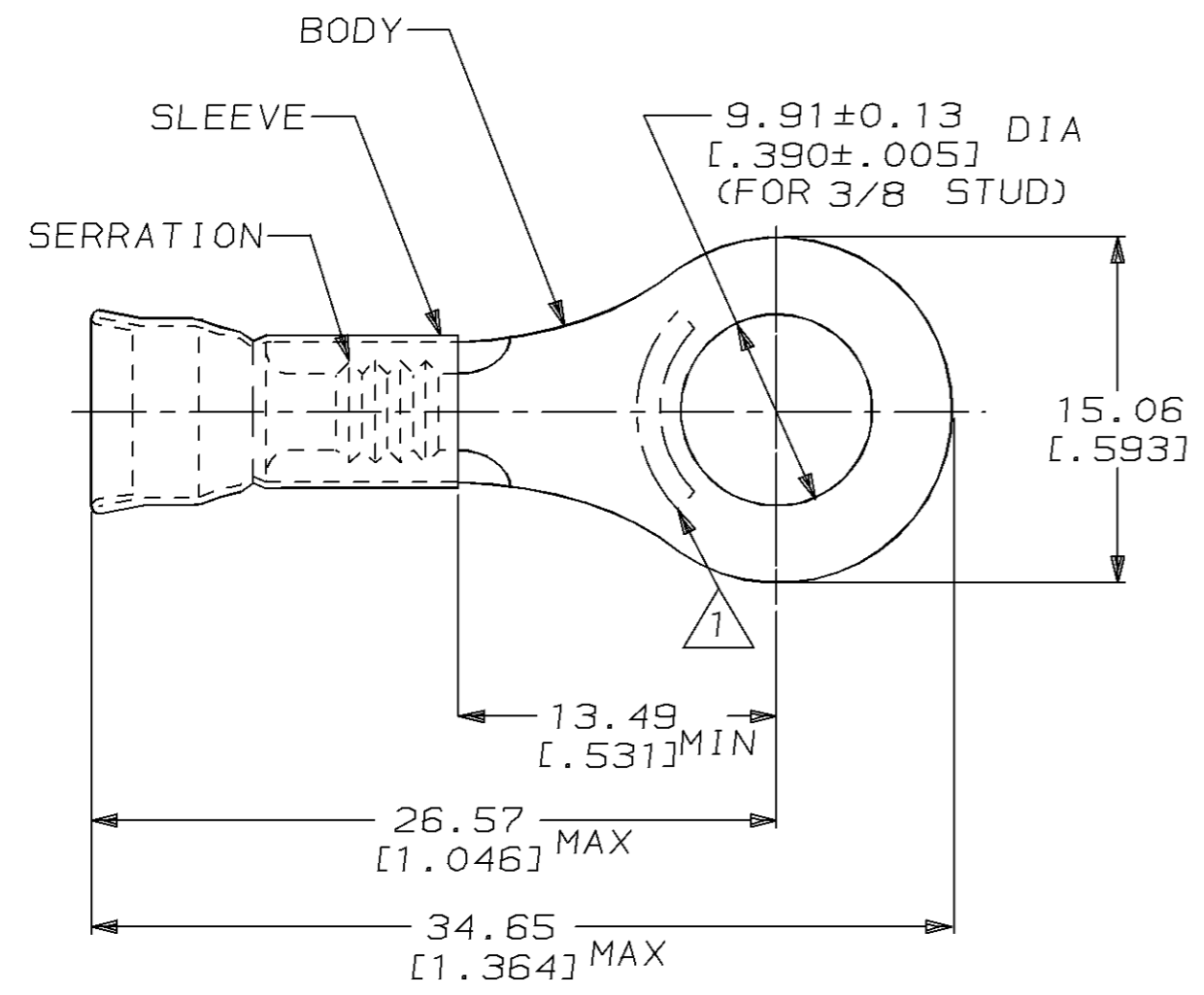

1. STAMP AMP 12-10* LOCATE APPROX AS SHOWN

- 2. WIRE INSUL DIA, 3.81-5.84 [.150-.230]
- 3. TONGUE MATL THK, 1.02±0.05 [.040±.002]

-	-	-
500	LOOSE PIECE	31828
QTY	PACKAGE TYPE	PART NO

AMP INCORPORATED CUSTOMER SERVICE SYSTEM		MAX RECOMMENDED OPERATING TEMPERATURE: 170°C [338°F]	THIS DRAWING IS A CONTROLLED DOCUMENT FOR AMP INCORPORATED. IT IS SUBJECT TO CHANGE AND THE CONTROLLING ENGINEERING ORGANIZATION SHOULD BE CONTACTED FOR THE LATEST REVISION.		DWN L OLMEDA 23JAN95	AMP AMP Incorporated Harrisburg, PA 17105-3608
FOR ADDITIONAL PRODUCT INFORMATION OR COPIES OF DRAWINGS AND TECHNICAL DOCUMENTS	PRODUCT INFORMATION CENTER 1-800-522-6752		DIMENSIONS: mm [in]	TOLERANCES UNLESS OTHERWISE SPECIFIED:	CHK M ELLIS 23JAN95	
FOR APPLICATION TOOLING INFORMATION	TOOLING ASSISTANCE CENTER 1-800-722-1111	VOLTAGE RATING: -		0 PLC ±-	1 PLC ±-	NAME TERMINAL, RING, DIAMOND GRIP, WIRE SIZE, 12-10 AWG
FOR ORDER ENTRY	1-800-526-5142	CIRCULAR MIL AREA: 2.62mm²-6.64mm² [5180-13100]		2 PLC ±0.20 [0.008]	3 PLC ±-	4 PLC ±-
			MATERIAL BODY, CU, SLV, CU PER ASTM B152	FINISH TIN PLATE PER MIL-T-10727	WEIGHT -	SIZE A3
			CUSTOMER DRAWING		CAGE CODE 00779	DRAWING NO C-31828
					SCALE 4:1	SHEET 1 OF 1
					REV C	